

Canopy
Mini Pureline 90 cm
Mineral Black



EAN 5414425259236

Energy label

▪ Energy Efficiency class (EEIhood)	A+
▪ Annual Energy Consumption (kWh/year) (AEChood)	33,8
▪ Fluid Dynamic Efficiency class (FDEhood)	A
▪ Lighting Efficiency class (LEhood)	A
▪ Grease Filtering Efficiency class (GFEhood)	D

Functions & features

▪ Motor	Integrated
▪ Sound absorber	Integrated
▪ Recirculation	Optional
▪ InTouch function	Standard
▪ Auto stop	▪
▪ Delayed switch off (minutes)	10
▪ Grease filter	7400020
▪ Number of grease filters	1
▪ Grease filter cleaning indication	▪
▪ Recirculation filter cleaning indication	▪
▪ Control method	Push buttons + Remote control
▪ Number of speeds	3 + power
▪ Automatic Power revert (minutes)	6

Dimensions

▪ Product dimensions (WxDxH) (mm)	860 x 301 x 330
▪ Width flange (mm)	10
▪ Dimensions cut-out opening (WxD) (mm)	845 x 286
▪ Min dimensions cabinet (WxDxH) (mm)	x 600 x
▪ Suitable for installation in a bottomless cabinet	-
▪ Advised mounting height induction hobs (Hmin-Hmax) (mm)	650 - 850
▪ Advised mounting height gas hobs (Hmin-Hmax) (mm)	650 - 850
▪ Advised mounting height ceramic hobs (Hmin-Hmax) (mm)	600 - 850
▪ Diameter outlet (mm)	150
▪ Position exhaust	Right, Top, Left, Back, Front

Lighting

▪ Functional lighting type	LED
▪ Functional light dimmable	▪
▪ Soft-ON/OFF	▪
▪ Number of functional lights	4
▪ Total energy consumption functional light (W)	8
▪ Color functional light (K)	2700/4000

Airflow and noise level

▪ Free airflow (m ³ /h)	815
▪ Airflow (m ³ /h) measured according to EN 61591	
▪ Sound regulation according to EN 60704-2-13	
▪ Airflow duct out speed 1 (m ³ /h) / Max pressure duct out speed 1 (Pa)	237 / 79
▪ Airflow duct out speed 2 (m ³ /h) / Max pressure duct out speed 2 (Pa)	379 / 225
▪ Airflow duct out speed 3 (m ³ /h) / Max pressure duct out speed 3 (Pa)	451 / 329
▪ Airflow duct out max powerspeed (m ³ /h) (Qboost) / Max pressure duct out max powerspeed (Pa)	601 / 372
▪ Sound pressure duct out speed 1 (dB(A)) / Sound power duct out speed 1 (dB(A))	26 / 37
▪ Sound pressure duct out speed 2 (dB(A)) / Sound power duct out speed 2 (dB(A))	36 / 48
▪ Sound pressure duct out speed 3 (dB(A)) / Sound power duct out speed 3 (dB(A))	40 / 52
▪ Sound pressure duct out at max powerspeed (dB(A)) / Sound power duct out at max powerspeed (dB(A)) (LWAboost)	47 / 59

Technical specifications

▪ Maximum power (W)	121
▪ Voltage appliance (V)	220-240
▪ Frequency (Hz)	50-60
▪ Power consumption in stand-by-mode (Ps) (W)	0.25
▪ Net weight (kg)	11,9
▪ Length power supply cable (m)	1,3

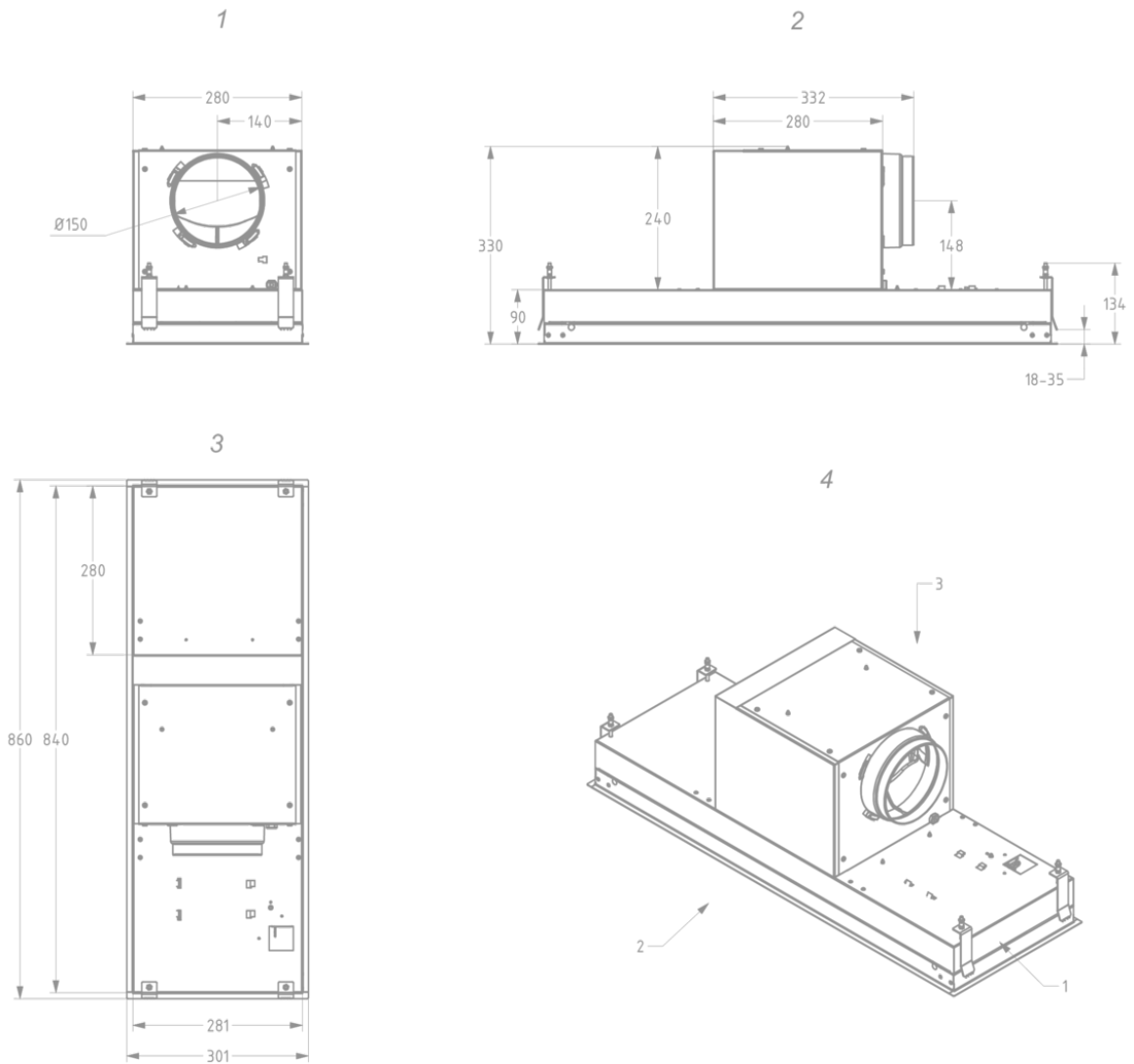

Installation accessories

Dissociated motor

- 800996

Kit to install remote motor Novy Mini Pureline

Extension cable

- 7000094

Extension cable for remote motor - 5 m

Accessories

Recirculation kit

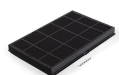

820400

Recirculation set Novy Mini Pureline 820, 821, 826

Recirculation box



841400

Exhaust box with monoblock filter



842400

Exhaust box with monoblock filter

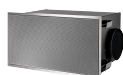

843400

Exhaust box with monoblock filter



7931400

Exhaust box with monoblock filter



7932400

Exhaust box with monoblock filter



7933400

Recirculation box with monoblock filter

Accessories

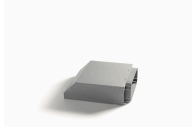
Adapter for limited installation height

830053

Adapter limited installation height Mini/Maxi Pureline

Control kit

990030

Kit connection with external cover and/or lighting

